

# Flat Panel Display System Upgrade Cockpit I/P<sup>®</sup> for Boeing 757/767



**INNOVATIVE  
AEROSYSTEMS**

## Affordable Upgrade Solutions for the B757/B767

### Integrated Flat Panel Cockpit Display System

Upgrading a cockpit is an economical way to extend an aircraft's life, increase its residual value and bring efficiency and safety benefits to every day operations. Innovative Aerosystems' Cockpit/IP® Flat Panel Display System (FPDS) is an FAA, Transport Canada and EASA certified, easily installed upgrade for owners and operators of Boeing 757/767 aircraft. The system is designed to replace the legacy EFIS, reducing component count while using EFIS wiring. The FPDS unique design provides fuel savings through power and weight reduction, can reduce delays and cancellations through increased dispatch reliability (3-Day MEL relief ETOP, 10-Day non-ETOPS) and provides enabling technology for future capabilities ensuring a state-of-the-art flight deck.

The IA Cockpit/IP consists of a pilot and copilot Primary Flight Display/Navigation Display (PFD/ND) suite, containing four (4) 6" x 8" Display Units (DU) and two (2) Display Control Panels (DCP) located in the forward center pedestal and three (3) 6 MCU Data Concentrator Units (DCU) installed in the electronics bay. By eliminating a number of older or obsolete components the Cockpit/IP, designed to support existing aircraft wiring, provides simplicity and flexibility allowing aircraft to be retrofitted within the window of a routine maintenance visit check. A digital Engine Indicating and Crew Alerting System (EICAS) is an included enhancement by adding a Display Unit that is the same part number as the PFD/ND along with two (2) scan converter modules that connect to the existing CRT connectors. The two ND's serve as the back-up to the EICAS display for redundancy.

The FPDS will meet your needs as mission requirements evolve and future technology is changing at a rapid pace. The Cockpit/IP provides a path to support emerging technologies such as Required Navigation Performance (RNP), Enhanced and Synthetic Vision (EVS and SVS) and it will align to current and emerging OEM platforms.

### FPDS Features:

- Class 3 forward field of view E-Charts
- Cross-side source selection
- Designed to support ADS-B and CPDLC
- Mitigates CRT Obsolescence
- Designed for minimal downtime during installation
- Flexible configurations to meet your needs
- Fully redundant system with fault tolerant dispatchability
- EFB overlays on ND/MFD
- Moving map with satellite weather graphics
- Turn-key package provided with panels, harnesses, and equipment
- High resolution displays with LED backlighting
- Upgradable to NextGen and SESAR requirements
- Digital Engine Indication and Crew Alerting System (EICAS)

767 EFIS



767 with FPDS



# FPDS Architecture:

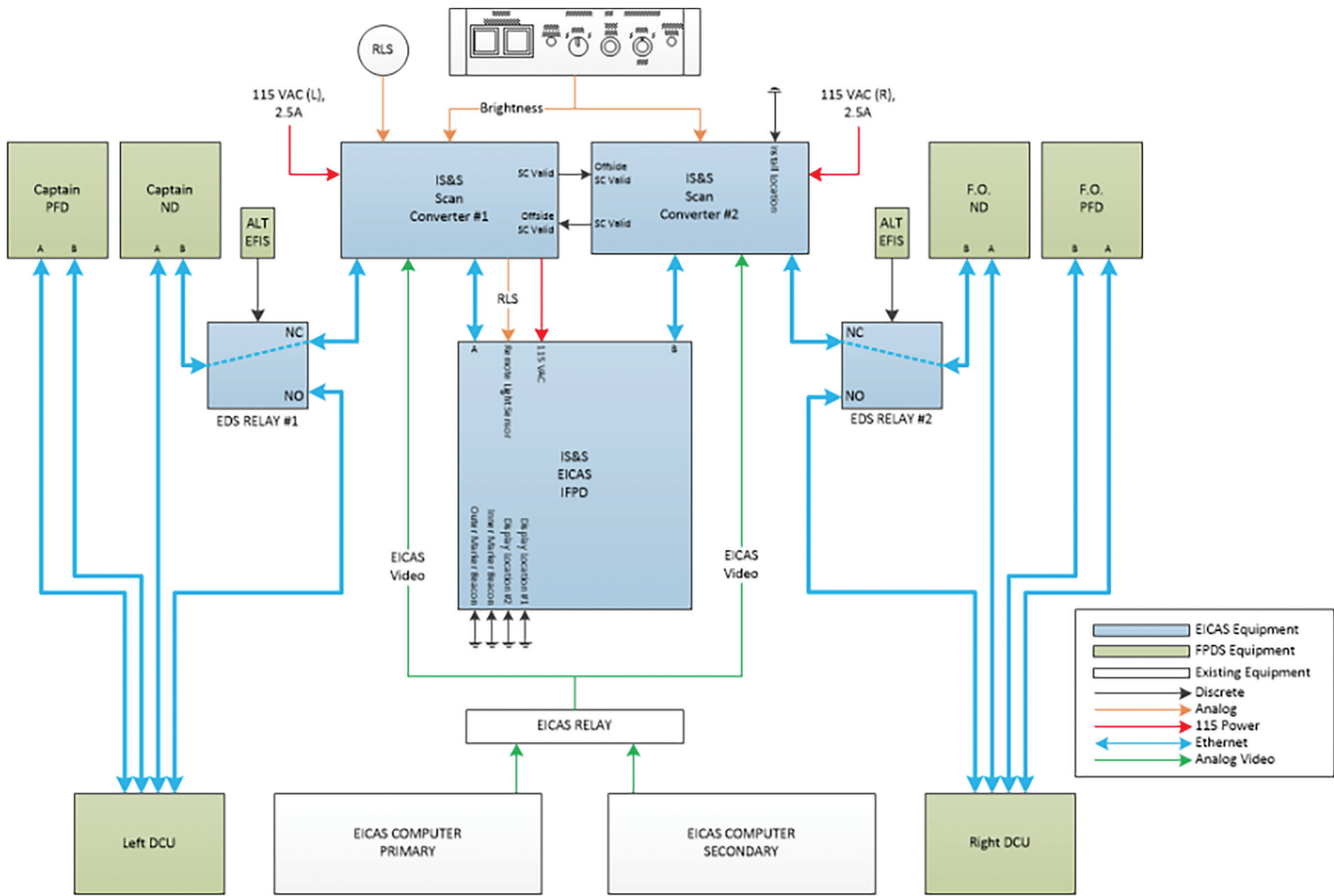

## PFD/ND Format:

The standard Primary Flight Display/Navigation Display (PFD/ND) format is based on industry standards and aligns the IA flight deck with new aircraft in production. Because of the available display area of the IA display units, the design goes a step further and provides the ability for flight crews to select expanded or centered (360 degree compass rose) information of the PFD unit. This feature allows pilots to select flight information, map, weather, traffic and terrain data for display on one or both primary flight displays to safely and efficiently fly an aircraft. This approach is certified with Level C dispatch relief approval, as detailed in the FAA Minimum Equipment List (MEL), to allow or three day (Extended Twin-Engine Operations) ETOPS or ten day Non-ETOPS relief to continue operating the aircraft with a display or a display control panel failed. In the event of a PFD failure, the PFD image is automatically driven to the ND display without any pilot action necessary.

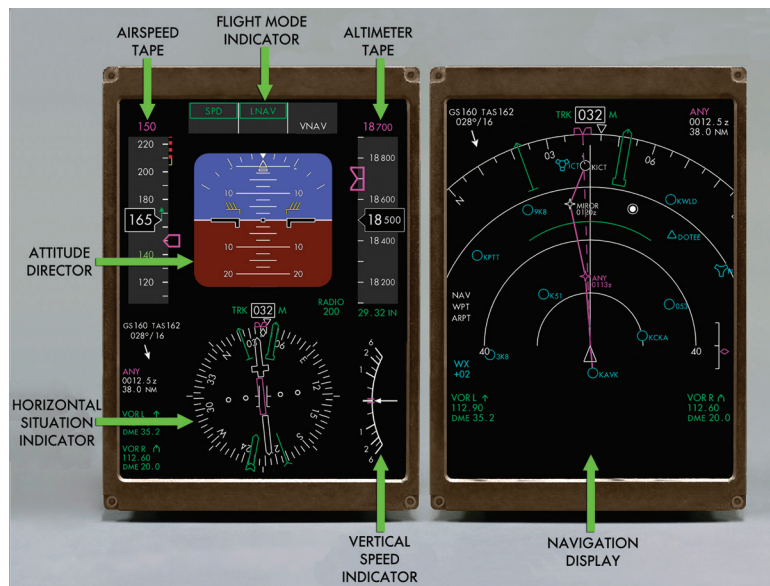



## The Innovative Aerosystems Advantage

The IA Cockpit/IP® replaces existing B757/B767 EFIS displays and symbol generators with minimal wiring changes. The display system incorporates the functionality of the existing electromechanical altimeter, airspeed, RDMI and vertical speed instruments to minimize training.

### Enhanced Readability

- High resolution multi-color LCD flat panel display
- Exceptional cross cockpit viewing angle
- Automatic luminance control

### LRU Reduction

- LRUs (part numbers) reduced
- Component count reduced by 80%
- Logistics savings

### Improved Dispatch Reliability

- Digital electronics for improved accuracy and dependability
- Provides MEL Relief (Level C, 10 Day)
- Can dispatch with failed DU or DCP
- Triple redundant channels in data concentrator
- Reduced down time and operation costs

### Adaptable to Future Requirements

- Flexible graphic symbology for user customization
- On-aircraft software updates
- Conforms to 767-200/300ER, 757-200 /-300, and 767-400 presentations



### Heat and Weight Savings

- Light weight design - removes over 220 lbs. in legacy equipment
- Reduced power consumption by 92 watts
- No forced air cooling required

### Minimal Pilot Training

- Human interface and display graphics designed for minimal pilot differences training
- Approved B-Level difference training program for B757/B767 models

### Options

- Integrated Standby Unit (ISU)
- Maintenance Pages
- Live motion video
- Class 3 E-Charts with ownship position

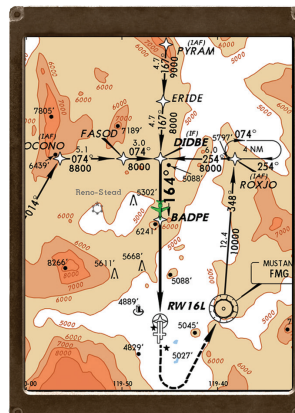

## System Specifications



### Display Unit (DU):

Each DU is a self contained display unit with integral Symbol Generator Unit (SGU) and power supply processor, offering superior performance with the following features:

- High resolution (768 x 1024 pixels) XGA multi-color LCD flat panel display
- 6-inch x 8-inch (152mm x 203mm) active area (combined 12" x 8" display area)
- All digital electronics with improved accuracy, dependability and responsiveness
- Readability in bright sunlight
- Flexible advanced graphics processing
- Non-glare, anti-reflective display surface
- Highly efficient uniform display lighting design
- Built-in-Test
- DO-160D Environmental Qualification
- DO-178B Software, Level A
- Patented Zoom Feature



### Display Control Panel (DCP):

The Display Control Panel provides pilot/copilot inputs and transmits data to the Data Concentrator Unit on a low speed ARINC 429 bus. The IA DCP directly replaces the current DCP using the same connector:

- Speed Reference Settings
- Minimum Selection (Radio or Baro) Units Selection
- Barometric Altimeter Setting
- Flight Path Vector
- Meters Altimeter
- Navigation Display Range
- PFD/ND and EGPWS/TERR Brightness Control
- Navigation Display mode
- MAP Display Overlay Selections

\*EFB Interface (Optional)



### Data Concentrator Unit (DCU):

The DCU is capable of handling 38 ARINC 429 inputs and 19 ARINC 429 outputs; 4 channels of ARINC 708 data; and 96 discrete inputs and 16 discrete outputs. Each DCU is designed to directly replace the current symbol generators using the same mount and connector. Three identical channels within the DCU provide a triple redundant set of data of the DUs for display processing. The DCU replicates the existing instrument outputs, and interfaces with the following typical aircraft components (as applicable):

- Air Data System (ADS) - Dual Redundant
- Automatic Direction Finder (ADF) - Dual Unit
- Distance Measuring Equipment (DME) - Dual Redundant
- Enhanced Ground Proximity Warning System (EGPWS)
- Flight Control Computer (FCC) - Triple Redundant
- Flight Management Computer (FMC) - Dual Redundant
- Inertial Reference System (IRS) - Triple Redundant
- Instrument Landing System (ILS) - Triple Redundant
- Mode Control Panel (MCP) - Single Unit
- Radar Altimeter (RA) - Triple Redundant
- Stall Warning Computer (SWC) - Dual Redundant
- Thrust Management Computer (TMC) - Single Unit
- Traffic Collision Avoidance System (TCAS) - Single Unit
- VHF Omni-directional Radio (VOR) - Dual Redundant
- Weather Radar (WXR)
- Windshear Computer (SWC) - Dual Redundant

### Integrated Standby Unit (ISU): Optional

The ISU calculates, processes and displays altitude, attitude, airspeed, slip/skid, and navigation display information in a logical and concise single instrument display. The unit is designed to support additional enhancements for Radio Management and Alternate Navigation (ILS, VOR, DME, ADF, FMS, GPS) functionality.



# System Options - Software

## PFD Format

- Baseline
- Expanded Horizon



## Required Navigation Performance Scales

### Expanded RNP Vertical Scales

- Customer defined options for Expanded Vertical Path Scale
- Magenta or Cyan pointer and CDI cue
- U Bracket or I Beam depiction
- Patented Zoom feature for VNAV path exceedance



## Flap Call Out

Display of flap position call out on airspeed tape:

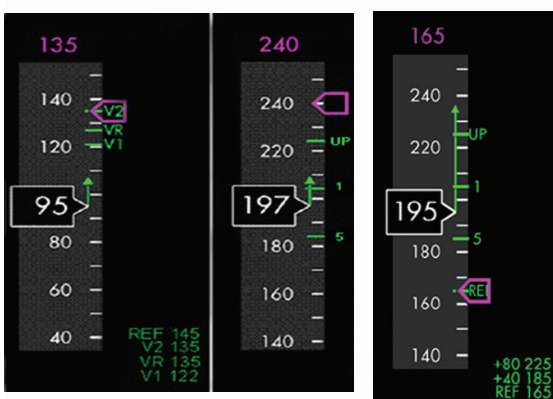

Jeppesen is a registered trademark of Jeppesen Sanderson, Inc.

## Transition Altitude Alert

Display and alert of selected Barometric Transition Altitude.

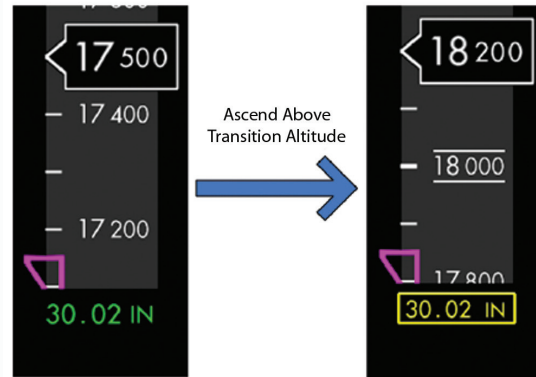

## Chronograph

Remove mechanical chronograph

- Displayed on PFD and ND Displays
- Interfaces with glareshield clock switch control

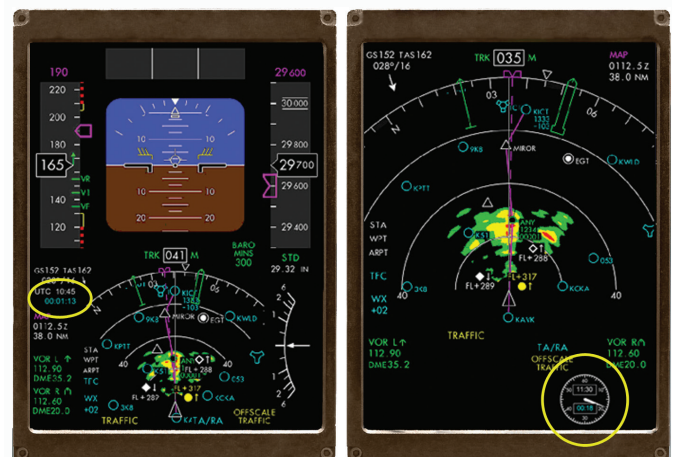

## Cockpit Portal

Supports EFB Applications

- Charts with Ownship Position
- Video
- Electronics Checklist
- Satellite Weather

## Level C Ownship Position

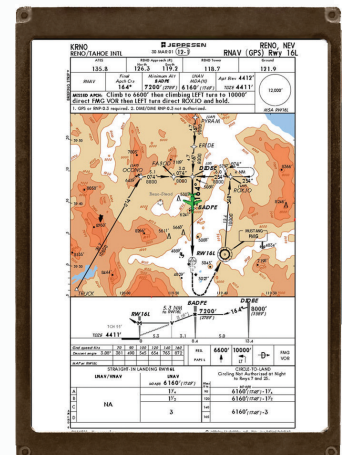
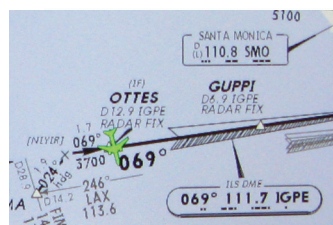



Data Sheet and all information contained in it is proprietary to Innovative Aerosystems  
All specifications are subject to change without notice from manufacturer.

Innovative Aerosystems is the world's leading supplier of RVSM solutions and a trusted integrator of Cockpit Information Systems (Cockpit/IP®) across the Commercial Air Transport, Military, and Business Aviation markets. We deliver advanced, cost-effective avionics by incorporating leading-edge technologies into proven, mission-ready systems for the global aerospace industry.



Corporate Headquarters:  
720 Pennsylvania Drive  
Exton, PA 19341 USA  
+1 610 646 9800 phone  
[www.iascorp.com](http://www.iascorp.com)

Innovative Aerosystems products  
identified in this document are  
covered by one or more Patents  
identified on [iascorp.com](http://iascorp.com)